

PROFIBUS

The perfect fit
for the process industry



profibus



SIEMENS

Reduce your total cost of ownership - with the flexible fieldbus for all requirements of the process industry

"Hybrid industry users in the chemical, pharmaceutical or food & beverage industries can benefit from PROFIBUS' unique value proposition in its ability to seamlessly integrate process instrumentation, like pressure transmitters and flow meters, with devices for the discrete side of the application, like drives and sensors."

*ARC Study May 2004
"The Value Proposition of PROFIBUS in the Hybrid Industries"
ARC Advisory Group, Dedham/MA, USA*

Production processes in the process industry are often "hybrid". Primary processes characterized by activities such as reaction, mixing or separation are combined with discrete applications of the secondary processes, the inbound or outbound logistics. Characteristic of these production applications are activities such as identification, transport, testing, filling, packaging or storing.

The demands placed by these characteristics on the fieldbus are totally different. Direct connection of intrinsically-safe devices and their power supply over the communications medium as well as the high information content of the communication are of great significance to the automation of the process engineering processes which are frequently carried out in environments which are corrosive, dangerous to health or explosive. On the other hand, speed and a strict real-time response are of prime importance for the production applications.

PROFIBUS is the only fieldbus worldwide which can currently cover all these requirements. With transmission technologies which supplement each other, a uniform communications profile, and additive application profiles for typical device functionalities, e.g. PA Devices, PROFIdrive or PROFIsafe, it is able - like no other - to uniformly combine process engineering and production areas together. Further application profiles enable existing installations with 4 to 20 mA technology and HART devices to be seamlessly integrated, thus providing permanent safeguarding of the associated investments.

Such a homogenous fieldbus architecture provides enormous cost advantages. Of prime significance are the reduced costs for design, assembly and wiring, but also for planning, engineering, commissioning and testing as well as documentation and training.

However, even greater significance can be applied to the lasting cost savings which can be achieved through efficient asset management for maintenance and in long-term operation.

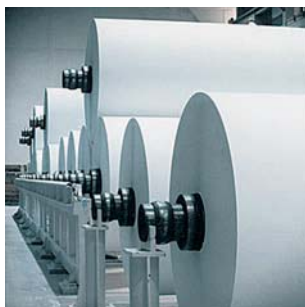

Contents

PROFIBUS - a uniform fieldbus for the complete process automation	4
Your advantages with PROFIBUS	7
PROFIBUS - proven and future-oriented	8
Technical basis	
General features and standards.	9
PROFIBUS DP and PROFIBUS PA versions.	10
PROFIBUS in hazardous areas.	12
Safety-oriented communication	13
Device management with GSD and EDD	14
Interoperability and interchangeability	15
Bus architecture	
PROFIBUS DP architecture	16
PROFIBUS PA architecture.	17
Configuration and diagnostics	
Configuration and diagnostics.	20
PROFIBUS cycle times and their calculation	21
Application examples	
Norsk Hydro Energy - oil & gas platform.	22
Bitburger brewery, Germany	23
Siemens process I/O for PROFIBUS	
Distributed I/O devices	24
Drives	25
Measuring equipment.	26
Process controllers.	28
Positioners	28
Process monitoring	28
Weighing and dosing systems	28
Analyzers	29

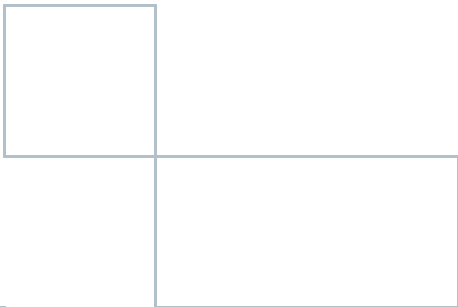

PROFIBUS - a uniform fieldbus for the complete process automation

Control • Distributed control system

INBOUND

Fieldbus requirement:
high speed, real-time,
deterministic: PROFIBUS DP

Convey



Main PROFIBUS devices:

- Motor starters (SIMOCODE, SIRIUS)
- Drives (SINAMICS)
- Dynamic weighing system
Belt scale

Identify



Main PROFIBUS devices:

- Operator panels (SIMATIC HMI)
- Barcode + ID readers (MOBY)
- Distributed IOs (SIMATIC ET 200)



Inspect



Main PROFIBUS devices:

- Machine vision (SIMATIC Machine Vision)
- Distributed IOs (SIMATIC ET 200)
- Valve positioners (SIPART PS)

Physical implementation:

-  PROFIBUS DP
-  PROFIBUS PA

Process Control

- DCS: SIMATIC PCS 7
- PLC: SIMATIC S7-300, S7-400
- Parameterization, asset management (SIMATIC PDM)

PRIMARY PROCESS

React



Main PROFIBUS devices:

- Distributed I/Os (SIMATIC ET 200)
- Level, pressure, temperature transmitters (SITRANS L, P, T)
- Analysis (ULTRAMAT, LDS6)
- Gas chromatography (Maxum)

Separate



Main PROFIBUS devices:

- Flow transmitters (SITRANS F)
- Level transmitters (SITRANS L)
- Motor starters (SIMOCODE, SIRIUS)

Mix



Main PROFIBUS devices:

- Flow, level, pressure, temperature transmitters (SITRANS F, L, P, T)
- Weighing system (SIWAREX)
- Motor starters (SIMOCODE, SIRIUS)

Pack/Fill



Main PROFIBUS devices:

- Drives (SINAMICS, SIMATIC-Technology, SIMOTION)
- Fail-safe systems (SIMATIC F systems)
- Distributed I/Os (SIMATIC ET 200)

Fieldbus requirement: high speed, high data transfer, redundant: PROFIBUS DP and 2-wire devices, operation in hazardous area: PROFIBUS PA



SECONDARY PROCESS

Fieldbus requirement: high speed, real-time, deterministic: PROFIBUS DP

Store



Main PROFIBUS devices:

- Pressure, temperature transmitters (SITRANS P, T)
- Analyzers (ULTRAMAT, OXYMAT,)
- Distributed IOs (SIMATIC ET 200)

Convey



Main PROFIBUS devices:

- Drives (SINAMICS)
- Motor starters (SIMOCODE, SIRIUS)
- Distributed IOs (SIMATIC ET 200)

Identify



Main PROFIBUS devices:

- Barcode + ID readers (MOBY)
- Operator panels (SIMATIC HMI)
- Distributed IOs (SIMATIC ET 200)

OUTBOUND

Fieldbus requirement:
high speed, real-time,
deterministic: PROFIBUS DP

Your advantages with PROFIBUS

Cost reduction

- Minimization of total cost of ownership through uniform fieldbus communication:
 - For all sectors of the production, process and hybrid industries
 - In all areas of the production process
 - For the complete life cycle of the plant
- Reduced planning and engineering overhead as well as lower commissioning costs compared to conventional signal transmission using parallel point-to-point connections
- Direct linking of process instruments, especially in hazardous areas, saves wiring as well as the hardware systems for jumpering, distribution, power supply and assembly
- Safety Integrated system with safety-oriented PROFIBUS communication as cost-effective alternative to separate safety systems
- Effective asset management with prediction of remaining service life and planning of preventive maintenance

Increased availability and performance

- Redundancy and comprehensive online diagnostics
- Central parameterization and proactive maintenance with efficient management systems/tools
- No regular calibration of field devices necessary
- Fast and reliable communication, as well as high measuring accuracy

Flexibility and investment safeguarding

- Largest installed basis worldwide with more than 15.4 million installed PROFIBUS nodes, of which 2.8 million in the process industry
- Interoperability and replaceability with a spectrum of more than 2,500 devices and over 1,400 international suppliers
- Coexistence of simple and complex devices through uniform communications protocol and additive application profiles for specific device functions (e.g. PROFIdrive for drives, Ident for barcode readers or PA Devices for process devices)
Expandability and guaranteed compatibility of further developments
- Seamless integration of conventional 4 ... 20 mA and HART devices which are already installed
- International acceptance through technologies conforming to IEC and ISO
- Global support by PROFIBUS International with 25 regional organizations, 31 competence centers and 7 test laboratories

Protection of man and machine

- Seamless integration of safety communication with PROFIsafe instead of a separate safety bus
- High amount of information and bidirectional communication for enhanced diagnostics functions for faster and more exact fault detection and troubleshooting

Easy installation

- FISCO-conformant PROFIBUS devices mean that complex calculations of the intrinsically-safe current are unnecessary

PROFIBUS - proven and future-oriented

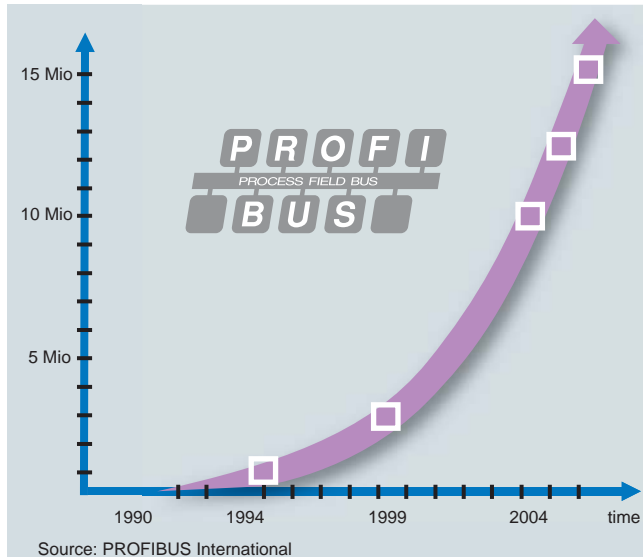

Installed PROFIBUS nodes

With its pioneering technology defined in international standards, PROFIBUS has developed into the global leader among the fieldbuses. This technology is characterized by

- use of open standards,
- compatibility,
- universal applicability,
- flexible expansion and
- high availability.

This is proven by the largest installed base worldwide with more than 15.4 million PROFIBUS nodes, of which 2.8 million are in the process industry with a share of approx. 530,000 PROFIBUS PA nodes (values at end of 2005).

PROFIsafe, which permits the transmission of safety-oriented data and control data on one bus cable, has also become established on the market and has gained a leading position in both process and production automation. More than 80,000 PROFIsafe nodes had already been delivered by the end of 2004 since the introduction of PROFIsafe technology in 1999.

All major manufacturers support the PROFIBUS standard with a total of more than 2,500 different products and services.

More than 1,400 vendors and user companies, including the world's leading suppliers of products and systems, have joined together to form PROFIBUS International (PI), the largest international fieldbus user organization. This strong and global organization promotes the expansion and continuous further development of PROFIBUS, and supports its members on all continents by means of a network of:

- 25 regional PROFIBUS organizations in 24 countries,
- 31 PROFIBUS competence centers in 16 countries,
- 7 authorized test laboratories and
- more than 50 working groups.

Comprehensive information on PROFIBUS International can be found on the Internet at www.profibus.com.

Totally Integrated Automation with PROFIBUS

PROFIBUS, as the communications medium in the field, is an important component of Totally Integrated Automation (TIA), the unique system offered by Siemens for uniform, customized automation of all sectors in the production, process or hybrid industries – starting at inbound logistics up to outbound logistics and for the complete life cycle of a plant.

Within TIA, expandability and safeguarding of investments are ensured through forward and backward compatibility.

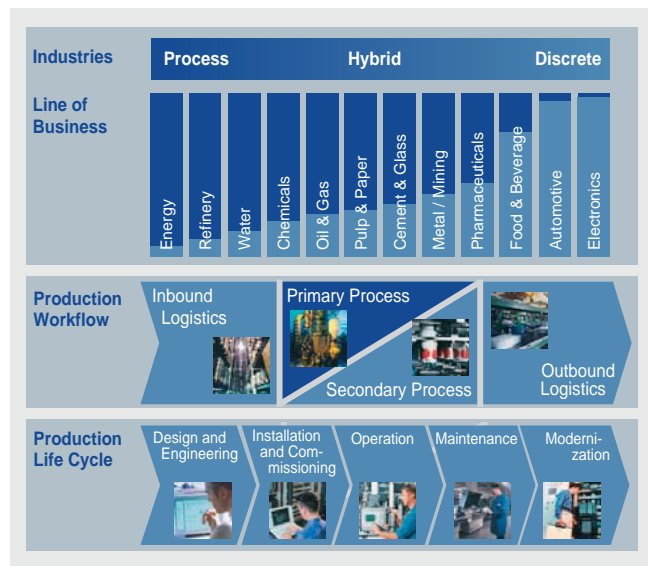

Field communication with PROFIBUS

General features and standards

Classification and features

In the process industry, conventional signal transmission between the sensors/actuators in the field and the input/output modules of the control system is implemented via parallel point-to-point connections with copper cables. Analog signals are usually transmitted with a level of 4 to 20 mA. 24 V DC or 110/230 V AC are used for digital signals.

In contrast to this, fieldbus systems such as PROFIBUS permit digital communication between the automation system (controller) and the field devices on a single serial bus cable. Such communication is characterized by cyclic transmission of process data and by acyclic transmission of alarms, parameters and diagnostics data.

The associated reduction in cabling overhead and input/output hardware represents enormous potential savings. The significantly greater information content of digital data transmission additionally implies significant cost advantages for plant operation and maintenance through:

- Bidirectional communication (definition of setpoint and reading of actual valve position)
- Comprehensive diagnostics information for asset management
- High accuracy (32-bit resolution)

PROFIBUS is simple, rugged and reliable, can be expanded on-line, and can be used in both non-critical environments and hazardous areas.

In addition to these properties, the following PROFIBUS functions are particularly relevant to process automation:

- Integration of previously installed HART devices
- Redundancy
- Safety-oriented communication with PROFIsafe
- Time synchronization
- Time tagging.

As a universal, open fieldbus, PROFIBUS handles

- fast communication with intelligent, distributed I/O devices (PROFIBUS with DP system) as well as
- communication and simultaneous powering for transmitters and actuators (PROFIBUS with PA system).

Thanks to its modular concept with mutually supplementing transmission technologies, a uniform communications protocol and a wide range of associated application profiles (e.g. PA Devices, PROFIsafe, PROFIdrive, Remote-I/O for PA, Ident systems or dosing/weighing), PROFIBUS is the only fieldbus which can be used in both the production and process industries.

International standardization

Standardization of the PROFIBUS initially started in 1991 with the German national standard DIN 19245 and in 1996 with the European standard EN 50170. PROFIBUS has been anchored in the international standards IEC 61158 and IEC 61784 since 1999.

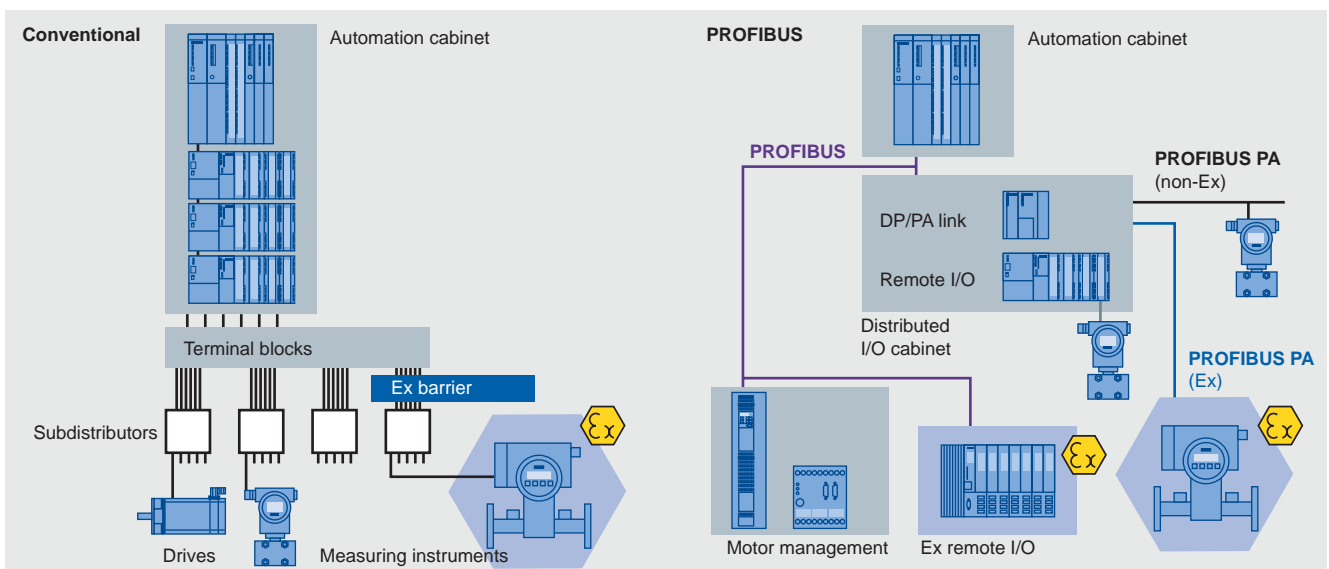

Design of PROFIBUS compared to conventional signal transmission

PROFIBUS DP and PROFIBUS PA versions

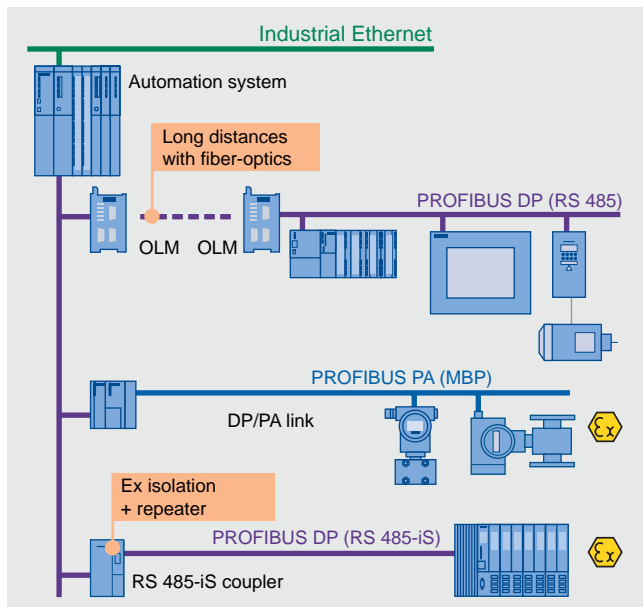

Transmission technologies with PROFIBUS

PROFIBUS DP

PROFIBUS DP is designed to provide high data transmission rates (up to 12 Mbit/s) and short response times (up to 1 ms) and is particularly suitable for direct control of

- intelligent field devices (e.g. motor starters, drives, analyzers, process controllers or panels) and
- distributed I/Os (remote I/Os such as ET 200M, ET 200iSP or ET 200S).

By combining the standard communications mechanisms of PROFIBUS with a special HART profile for mapping the client/master server model of HART on the PROFIBUS, the large installed base of HART devices in the field can be integrated into existing or new PROFIBUS DP communications networks. The advantage is that the same bus cable can be used for the actual PROFIBUS communication and for the HART communication with the distributed I/O stations.

Transmission technologies

PROFIBUS DP networks can be implemented with the following transmission technologies according to IEC 61158 and IEC 61784:

- **RS 485**
Simple and cost-effective electrical transmission technology on the basis of a shielded two-wire cable. An electrical PROFIBUS network can be configured with a linear or tree structure.

- **RS 485-iS**
Intrinsically-safe electrical transmission technology for hazardous areas up to Ex zone 1, implemented using a shielded two-wire cable with a transmission rate of 1.5 Mbit/s. Requires decoupling of RS 485 and RS 485-iS by an isolating transformer (RS 485-iS coupler).
- **Fiber-optic**
Optical transmission technology using glass or plastic fiber-optic cables, for fast transmission of large data quantities in environments with high interference or for covering large distances. The design of an optical network with a linear, ring or star structure is possible with optical link modules (OLM). The ring structure automatically provides fault tolerance in the event of a wire breakage. The maximum distance between two optical link modules can be 15 km. As a result of the almost loss-free optical transmission, the total size of the network is governed primarily by the propagation times.

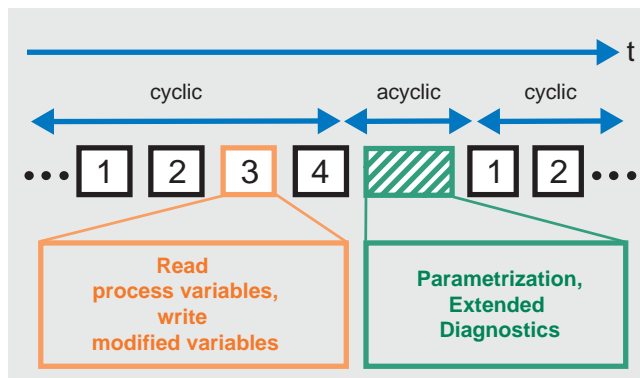

Deterministic bus communication of the PROFIBUS

Deterministic bus communication

A characteristic feature of the PROFIBUS is its deterministic real-time bus communication cycle resulting from the use of a master/slave principle which guarantees the bus cycle time and the defined response times of the participants on the bus. This is characterized by

- cyclic transmission of process data and
- acyclic transmission of configuration, alarm and diagnostics data.

The time window for acyclic communication is automatically set up during the configuration. If the amount of data is larger than this time window, the acyclic communication is broken up among several cycles.

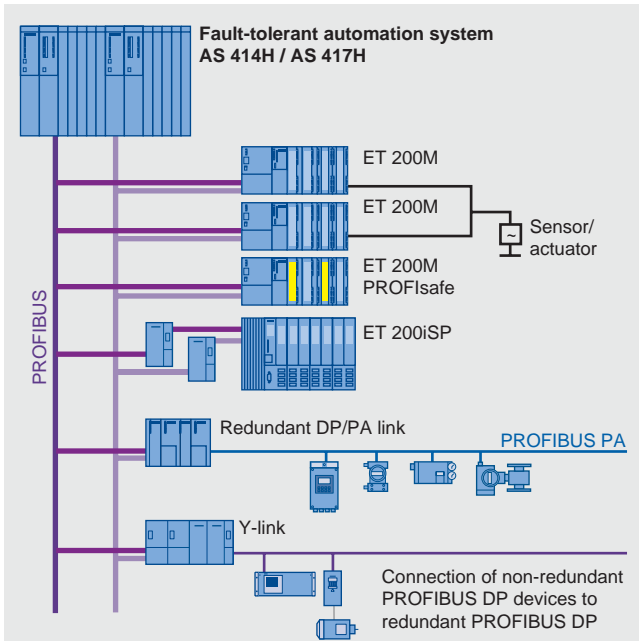

Redundant design of PROFIBUS DP

Redundancy

PROFIBUS DP can also be used in redundant architectures. Distributed I/Os are connected via two interface modules to two redundant PROFIBUS DP networks within a fault-tolerant automation system, and intelligent field devices on the PROFIBUS PA are connected via a redundant DP/PA link to two interface modules. Non-redundant PROFIBUS DP devices can also be operated in a redundant PROFIBUS DP architecture by using a Y-link.

PROFIBUS DP

- Designed to provide high data transmission rates (up to 12 Mbit/s) and short response times
- Suitable for direct control of
 - intelligent field devices (e.g. drives, motor starters, analyzers, process controllers or panels) and
 - distributed I/Os (remote I/Os such as ET 200M, ET 200iSP, ET 200S)
- Redundant operation as option
- Different physical transmission technologies (can be combined together specific to the application):
 - Two-wire copper cable for networks up to max. 10 km (RS 485 up to Ex zone 2, RS 485-iS up to Ex zone 1)
 - Fiber-optic for interference-free optical networks for large distances (> 15 km), up to Ex zone 1

PROFIBUS PA

PROFIBUS PA, which permits simultaneous transmission of digital data and powering of the bus by means of a two-wire cable and MBP intrinsically-safe transmission technology (Manchester Coded; Bus Powered), can be applied optimally in the process industry for the direct connection to devices such as pneumatic actuators, solenoid valves, sensors and analyzers in environments up to Ex zone 0 or 1.

Despite the seemingly low transmission rate of 31.25 kbit/s, the typical communication time of a transmitter is only approx. 10 ms. This means that practically all typical applications in the process industry can be implemented with minimal constraints on segment device density.

PROFIBUS PA can be designed with a linear or tree structure with long spur lines (up to 120 m). DP/PA couplers or DP/PA links are used for the supply of power and for adaptation of the data transfer rate from PROFIBUS DP to PROFIBUS PA.

PROFIBUS PA

- Designed to permit simultaneous transmission of digital data and powering of the bus by means of a two-wire cable and MBP transmission technology
- Allows placement of pneumatic actuators, solenoid valves, sensors and analyzers directly in environments up to Ex zone 0 or 1
- Can be designed with a linear or tree structure with segment cable lengths up to 1,900 m
- Short device communication cycle times (approx. 10 ms is typical for transmitters)
- By using components certified according to the FISCO model:
 - Enormous simplification of configuring
 - Omission of Ex circuit calculations
 - Maximizes the number of usable devices
 - Increase in cross-vendor variability
- Multi-vendor replaceability of field devices
- Ex Hubs permit a significant increase in the number of devices which can be connected per bus segment in the Ex area as well as in the cable length

Safety-oriented communication

Comparison between Zones and Classes/Divisions		
Standards	NEC 505	NEC 500
Atmosphere		
■ Gases, vapors	Zone 0	Class I, Division 1
	Zone 1	
	Zone 2	Class I, Division 2
■ Dusts	Zone 20	Class II, Division 1
	Zone 21	
	Zone 22	Class II, Division 2

FISCO model

For the design or extension of a PROFIBUS PA segment in a hazardous area, no complex intrinsically-safe circuit calculations are necessary if the components involved (Ex coupler, cable, field devices, bus terminator) are certified according to the FISCO model (Fieldbus Intrinsically Safe Concept) by an authorized approving authority, e.g. PTB or UL. This results in substantial cost savings in the planning and operating phases. Furthermore, no calculations whatsoever are required any more when adding or removing devices.

According to the FISCO model, a network is intrinsically-safe if the components mentioned observe defined limits for voltage, current, power, inductance and capacitance. When using components approved according to FISCO, e.g. intrinsically-safe DP/PA couplers and PA field devices from Siemens, the number of devices which can be operated on one segment can be maximized, and cross-vendor interchangeability is ensured when replacing an individual device or expanding a plant.

Safety-oriented communication with PROFIsafe

PROFIsafe is a profile which implements the fail-safe PROFIBUS communication between safety-oriented devices present in the field and a safety-relevant application executing in an automation system: up to KAT4 according to EN954, AK6 or SIL3 according to IEC 61508.

The PROFIsafe profile is implemented as an additional software layer within the device and automation system, without modifying the standard PROFIBUS communication mechanisms. Thus the standard components (e.g. communications modules, connectors or cables) involved in the communication of the two PROFIsafe participants can be used without modification. Furthermore, PROFIsafe devices can be operated in parallel with standard devices on the PROFIBUS, also in redundant architectures if required. PROFIsafe can also be used within intrinsically-safe applications.

PROFIsafe is designed fault-tolerant by taking into account possible faults occurring during serial bus communication, e.g. delay, loss, repetition or falsification of data, incorrect sequence or faulty addressing, preventing these by means of:

- Consecutive numbering of the safety telegrams
- Fixed time frame for incoming telegrams and their acknowledgment
- Identification between transmitter and receiver
- Additional data security (Cyclic Redundancy Check)

Device management with GSD and EDD

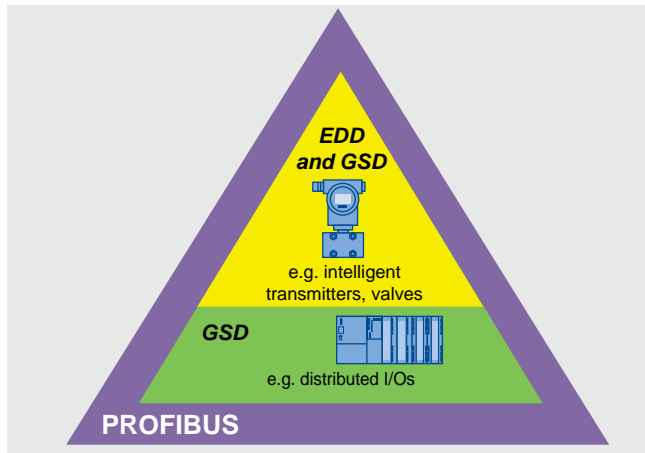

Efficient engineering with GSD and EDD

The intelligence of field devices and distributed I/O components has increased enormously in the past few years. These devices currently offer a scope of functions and information which was previously only provided by controllers.

The tools used for engineering, parameterization, commissioning, diagnostics, asset management and servicing (e.g. SIMATIC PDM) and for integration within higher-level controllers therefore require an exact and complete description of the device-specific data and functions, e.g.

- Type of application function
- Configuration parameters
- Dimensional units
- Limits and default values
- Ranges.

This description is provided by the vendor in the following form:

- as a device master file (GSD) for the cyclic data exchange between the PROFIBUS master and the PROFIBUS slaves, or
- as an Electronic Device Description (EDD) which includes both standard and vendor-specific properties for acyclic parameterization, diagnostics and monitoring of measured values.



Device master file GSD

The GSD is an ASCII text file in which the general and device-specific communications features of a PROFIBUS device are described using compulsory and optional keywords or parameters. Vendor and profile ID numbers increase the configuration reliability, and facilitate the replacement of devices.

The GSD file describes all parameters important for cyclic communication.

```
; Unit-Definition-List:  
GSD_Revision      = 2  
Vendor_Name       = "SIEMENS"  
Model_Name        = "DP/PA"  
Revision          = "V1.6"  
Ident_Number      = 0x8052  
Protocol_Ident    = 0  
Station_Type      = 0  
Hardware_Release  = "V2.2"  
Software_Release  = "V3.5"  
9.6_supp          = 1  
19.2_supp         = 1  
45.45_supp        = 1  
93.75_supp        = 1  
187.5_supp        = 1  
.....
```

Example of device master file

Electronic Device Description EDD

In the case of tasks based on acyclic communication, the EDD file which is generated by the device vendor using the powerful EDDL (Electronic Device Description Language) delivers the required device information. The EDD can be used for simple or complex devices. These tasks include:

- engineering,
- commissioning,
- diagnostics,
- measured-value monitoring,
- asset management or
- documentation.

The EDD standardizes the GUI in conjunction with the powerful SIMATIC PDM Process Device Manager. It is extremely convenient to generate, and requires no special knowledge. Existing EDDs, profile descriptions and text libraries can also be incorporated.

Interoperability and interchangeability

Interoperability

The interoperability of the PROFIBUS allows users to operate field devices from different vendors together on one controller. This is made possible by the GSD and EDD device descriptions. During configuration of the bus with the engineering system, the GSD file is used to generate the communications parameters for the PROFIBUS master. These define the characteristics and scope of functions for cyclic master/slave communication.

Using the EDD delivered by the device vendor, and together with a suitable engineering tool such as SIMATIC PDM, it is possible to define the specific device parameters for acyclic communication, e.g. for parameterization, diagnostics or monitoring of measured values.

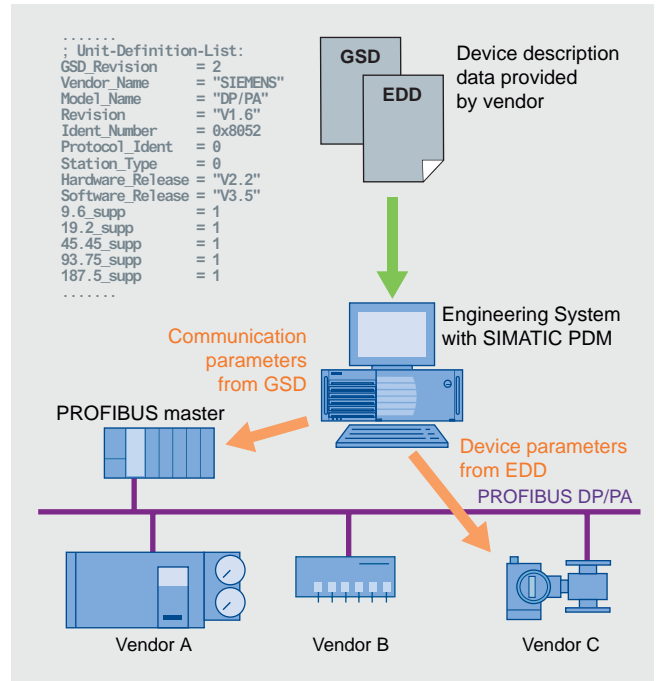

Representation of interoperability of devices from different vendors

Interchangeability

The PROFIBUS master recognizes the vendors and PA profiles of devices connected to the PROFIBUS by means of their GSD identification number. PROFIBUS devices from one profile family can be simply replaced by comparable devices from another vendor as a result of the "PA profile" which is independent of the vendor.

Such universal PA profiles are available e.g. for

- devices for counting,
- devices for measurement of pressure, flow or level,
- positioners,
- analyzers,
- digital input/output devices or
- multi-variable devices.

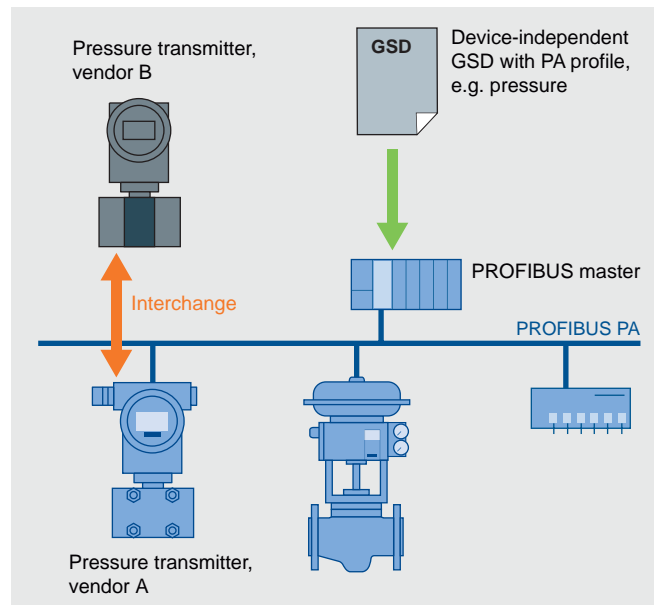

Representation of cross-vendor device interchangeability

PROFIBUS DP architecture

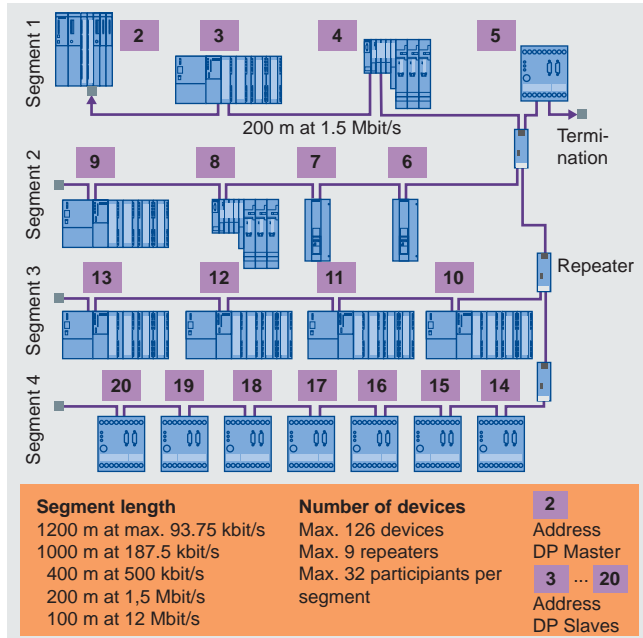

Electrical RS 485 network with linear/tree structure

Electric RS 485 network

The simple and cost-effective two-wire RS 485 transmission technology is exceptionally suitable for networks with a linear/tree structure and high data transmission rates. The total size of the network is smaller than with an optical network, but can also reach distances up to 1 km (at 12 Mbit/s) or up to 10 km (at 187.5 kbit/s) by using segments and by boosting the signal with up to 9 repeaters.

Special diagnostic repeaters can also be used instead of standard repeaters, and permit online monitoring of the connected bus segment in addition to boosting of the signal.

A segment can have up to 32 participants (master/slaves), and the total network up to 126 participants. The start and end of each segment must be terminated by an active bus resistor which is typically pre-integrated in the device (e.g. repeater) or is available as an active RS 485 termination element.

The configuration example (figure at top right) shows a typical addressing scheme for a PROFIBUS DP network made up of multiple segments.

Although repeaters are electrical participants on the PROFIBUS, they are not assigned a slave address since they are not directly addressed by the master.

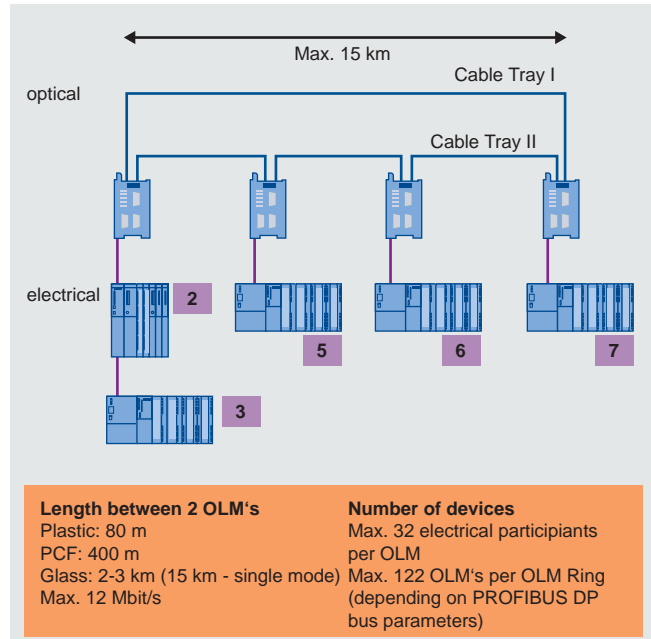

Configuration example of an optical ring combined with an electrical network

Optical ring

Although optical bus cables are more expensive than electrical RS 485 networks, they are immune to electromagnetic interference and can cover distances > 15 km at a data transmission rate of 12 Mbit/s when using glass fiber-optic cables.

In addition to purely optical networks, the combination of electrical and optical networks has been established in practice, providing users with the advantages of the respective transmission technologies.

A ring structure of the optical network provides fault tolerance since communication is not interrupted in the event that the cable is damaged at one point or interrupted. The electrical bus segments are incorporated into the optical ring using optical link modules (OLM). Up to 122 OLMs can be integrated in an optical ring, where the max. distance between two OLMs can be up to 15 km. A maximum of 32 electrical bus participants can be operated on one OLM.

The configuration example shows a typical addressing scheme with mixed transmission technologies. Although OLMs are electrical participants within their respective segment, they are not assigned a slave address on the PROFIBUS.

PROFIBUS PA architecture

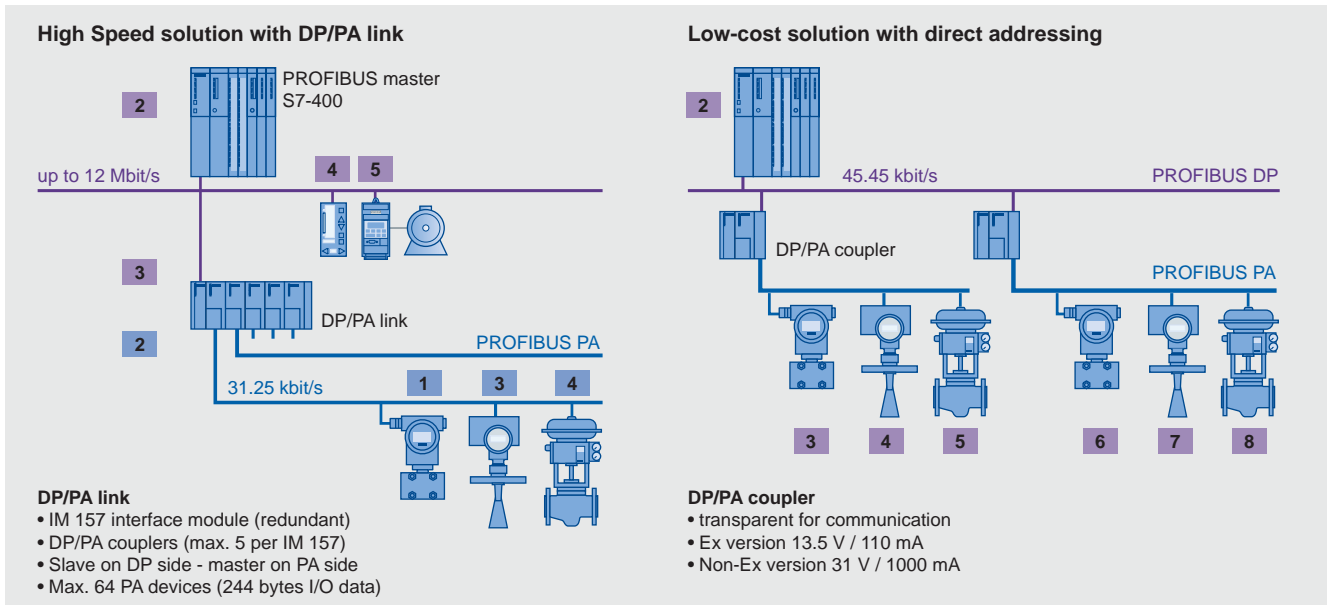

Configuration examples with DP/PA link and DP/PA coupler

Bus configuration with DP/PA coupler or DP/PA link

To create a smooth network transition between PROFIBUS DP and PROFIBUS PA, the SIMATIC product range offers the following two components:

- DP/PA coupler: for small signal quantities and low time requirements
- DP/PA link: for a large number of participants and high cycle time requirements

The DP/PA coupler is available in an Ex version with max. 110 mA output current and a non-Ex version with 1000 mA output current. These are mounted together with a 24 V DC load power supply on an S7-300 rail and can be installed in environments up to Ex zone 2. When using the DP/PA coupler, the data transfer rate on the PROFIBUS DP is limited to 45.45 kbit/s. The PROFIBUS PA slaves are addressed directly by the PROFIBUS master.

The DP/PA coupler is an electrical participant, but is transparent for communication between the master and PA field devices; it therefore does not require setting of parameters or addresses.

The DP/PA coupler is also an integral component of the DP/PA link which is a modular combination consisting of the PROFIBUS DP interface module IM 157 (with optional redundancy) and up to 5 DP/PA couplers (Ex or non-Ex version) packaged in an S7-300 design. The DP/PA link is mounted together with a 24 V DC load power supply on an S7-300 rail and can

be installed in environments up to Ex zone 2. Use of active bus modules on the backplane allows hot swapping of individual modules and a redundant design of the PROFIBUS DP interface module. By decoupling the transmission rates between PROFIBUS DP and PROFIBUS PA, a data transfer rate of up to 12 Mbit/s can be achieved on the PROFIBUS DP.

The DP/PA link functions as a slave on the PROFIBUS DP and as a master on the PROFIBUS PA. From the viewpoint of the host controller, the DP/PA link is a modular slave whose modules are the devices connected on the PROFIBUS PA. Addressing of these devices is carried out indirectly via the DP/PA link which itself only requires one DP address. When considering the speed and number of PA devices per PROFIBUS master (controller), this solution provides significant advantages compared to the solution with only a DP/PA coupler. The host PROFIBUS master can scan devices connected to the DP/PA all at once. The speed on the PROFIBUS DP is not influenced by the subordinate PROFIBUS PA, and DP devices can therefore be operated together with the PA devices on the same segment without a loss in performance. With 123 DP/PA links per PROFIBUS master and 64 PA devices per link, the combination of data permits operation of up to 7872 PA devices on just one PROFIBUS DP master.

PROFIBUS PA architecture

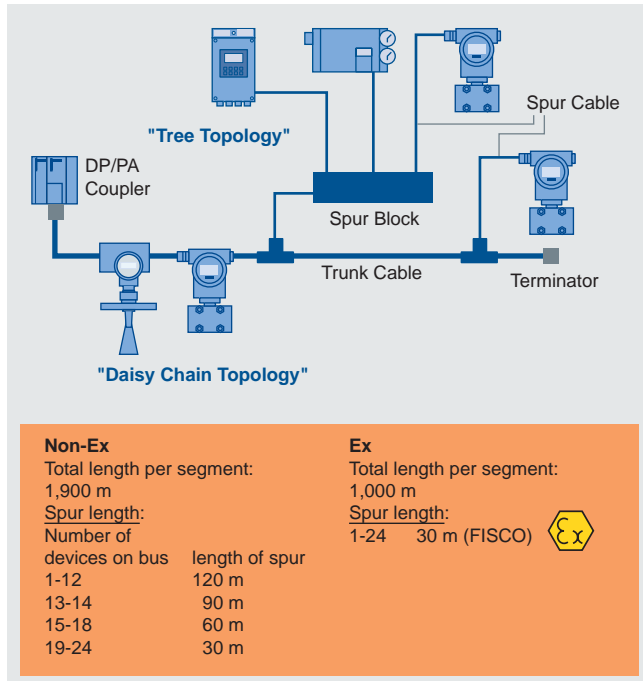

PROFIBUS PA topologies: linear and tree

Topologies

The PROFIBUS PA can be designed with tree and linear topologies (see graphic above).

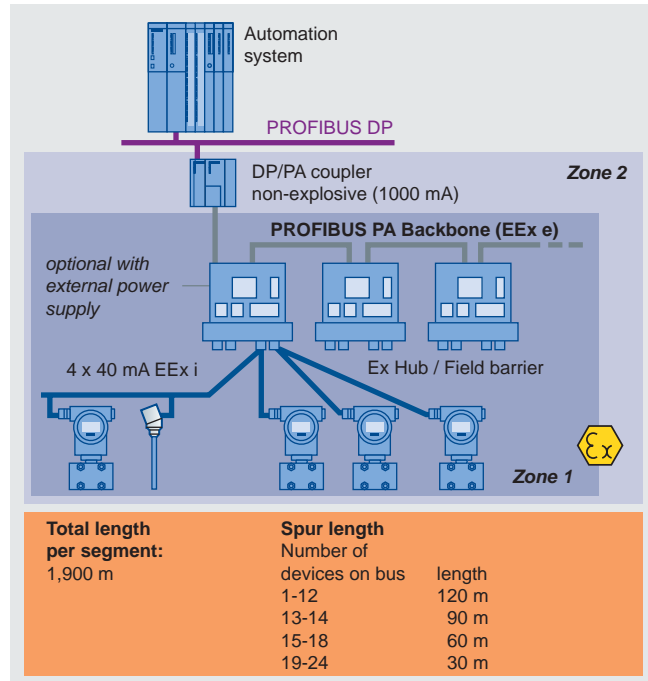

Example of PROFIBUS architecture with Ex Hubs/field barriers

Architecture with Ex Hubs/field barriers

Through electrical isolation of intrinsically-safe and non-intrinsically-safe PROFIBUS PA segments, Ex Hubs/field barriers from various vendors permit operation of intrinsically-safe devices on the non-intrinsically-safe DP/PA coupler in the DP/PA link. It is then possible to work with higher supply voltages and currents (1,000 mA), and the number of devices which can be connected per bus segment in the hazardous area is increased enormously. If necessary, Ex Hubs/field barriers can also be powered externally (24 V DC/ 120 V/230 V AC). This reduces the load on the PROFIBUS PA backbone to a minimum, and permits implementation of longer cable lengths.

The Ex Hub shown as an example in the figure can be installed in the Ex zones 1, 2, 21 or 22. It offers 4 intrinsically-safe (EEx i), short-circuit-proof feeders with 40 mA each which are suitable for connection of spur lines with a maximum length of 120 m. The total length of the bus segment (backbone including spur lines with type of protection EEx e) can be up to 1,900 m. The ability of the feeders to resist short-circuits means that a fault in one feeder has no feedbacks on the PROFIBUS PA backbone and the other feeders. A further advantage is that the devices can be integrated into existing bus structures without problem.

PROFIBUS PA architecture

Calculation examples

Technical specifications	
DP/PA coupler	
Voltage at coupler output	
■ Version for hazardous area	13.5 V
■ Version for non-hazardous area	31 V
Max. current at coupler output	
■ Version for hazardous area	110 mA
■ Version for non-hazardous area	1000 mA
PROFIBUS PA device	
Min. supply voltage	9 V
Typical current consumption	Approx. 12 mA
PROFIBUS PA cable	
Line resistance	Approx. 44 Ω/km

The number of devices which can be operated within one PROFIBUS PA segment depends on their current consumption and the line resistance.

Depending on the current or voltage at the output of the DP/PA coupler, the maximum number of devices as well as the maximum network size can be easily determined using Ohm's law.

Number of devices

Max. number of PA devices per segment =	$\frac{\text{Current at coupler output [mA]}}{\text{Typical current consumption per PA device [mA]}}$
■ DP/PA coupler for Ex area (110 mA / 12 mA):	9 devices
■ DP/PA coupler for non-Ex area (1000 mA / 12 mA):	83 devices, limited by PROFIBUS standard to: 31 devices

Max. cable length based on fully loaded PA segments

Cable length per segment [km] =	$\frac{\text{Voltage at coupler output [V] - Min. supply voltage for PA device [V]}}{\Sigma \text{ Current consumption of PA devices [A]} \cdot \text{Line resistance [}\Omega/\text{km]}}$
Examples:	
■ DP/PA coupler for Ex area	$(13.5 \text{ V} - 9 \text{ V}) / (0.11 \text{ A} \cdot 44 \Omega/\text{km})$ Approx. 0.92 km
■ DP/PA coupler for non-Ex area	$(31 \text{ V} - 9 \text{ V}) / (500 \text{ mA} \cdot 44 \Omega/\text{km})$: Approx. 1.00 km
	$(31 \text{ V} - 9 \text{ V}) / (1000 \text{ mA} \cdot 44 \Omega/\text{km})$ Approx. 0.50 km

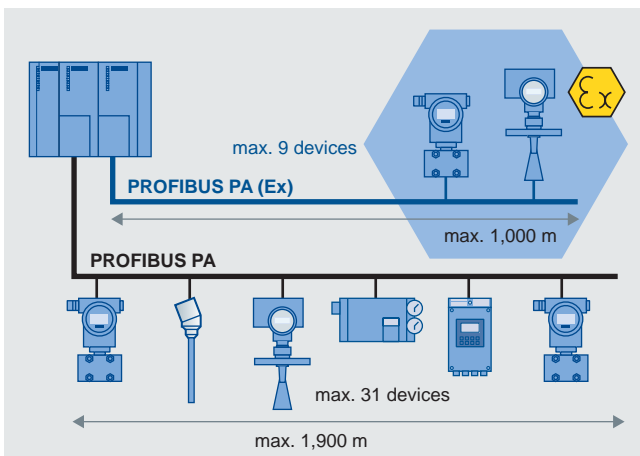

Maximum lengths per bus segment

Smaller loads permit correspondingly greater cable lengths.

Depending on the number of PA devices and their actual current consumption, the PROFIBUS standard allows the following maximum lengths:

- DP/PA coupler for Ex area: 1.0 km
- DP/PA coupler for non-Ex area: 1.9 km

Configuration and diagnostics

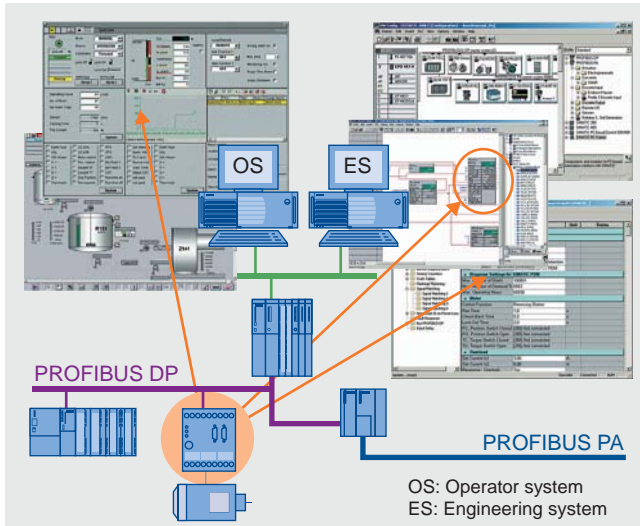

Configuration and diagnostics facilities

When used in a SIMATIC PCS 7 project, field devices and distributed I/O components are configured using the HW-Config tool for communication with the PROFIBUS master (controller). If they are not already integrated in the supplied hardware catalog, they can be subsequently added to the configuration environment by importing their GSD file. The GSD file is provided by the vendor, e.g. via PROFIBUS International on the Internet (www.profibus.com).

To implement the control strategy, a predefined function block representing the device function is linked in the CFC editor to other blocks. This block usually includes a faceplate for operation of the field device from the operator system.

The SIMATIC PDM Process Device Manager is used for enhanced configuration and online diagnostics. With support for more than 1,200 devices from Siemens and more than 100 vendors worldwide, SIMATIC PDM is a true multi-vendor configuration tool with the widest range of devices. Devices which are not yet supported can be integrated in a simple manner by importing their device descriptions (EDD).

PROFIBUS offers numerous diagnostics facilities which fall into the following categories:

- Communications and line diagnostics of the PROFIBUS network, especially for detecting wiring faults
- Diagnostics information of the intelligent field devices for maintenance or troubleshooting

Communications and line diagnostics

Numerous software tools from different vendors are available for communications and line diagnostics. These can be directly connected via a PC/notebook interface to the PROFIBUS network (e.g. Amprolyzer), and offer commissioning or servicing engineers comprehensive functions for bus diagnostics and analysis, including:

- Recording and interpretation of telegrams
- Automatic detection of transmission rate
- Lifelist of all bus participants
- Summary of current statuses of all bus participants
- Statistical evaluation of bus events.

The diagnostics repeater available for the connection of PROFIBUS DP segments with RS 485 technology combines two functions in one device:

- Connection and expansion of electrical networks including signal boosting and electrical isolation of the segments
- Online fault monitoring of the electrical bus lines of connected segments.

The diagnostics message sent by a diagnostics repeater to its PROFIBUS master in the event of a fault contains detailed information on the fault location, in addition to the cause of the fault, e.g. line interruption, short-circuit, terminating resistor absent, too many participants, or participants too far away.

Diagnostics of intelligent field devices

The standardized diagnostics mechanism of the PROFIBUS permits the user to rapidly recognize and eliminate faults in the devices connected to the bus.

The diagnostics messages from the field devices can also be utilized e.g. for early initiation of preventive maintenance measures as a result of abnormalities detected long before a device fails. If a fault occurs on the field device or if maintenance is necessary, e.g. because of contamination on a capacitive level sensor, diagnostics information is transferred, and a message sent to the operator station and the maintenance station for the SIMATIC PCS 7 asset management.

Enhanced diagnostics information providing details about the devices on the PROFIBUS (e.g. production date, operating hours counter, vendor information) can be provided by the vendor's EDD through SIMATIC PDM. To prevent unnecessary loading of the cyclic data exchange between devices, this information is controlled by acyclic mechanisms and automatically distributed among several bus cycles if the data quantities are large.

PROFIBUS cycle times and their calculation

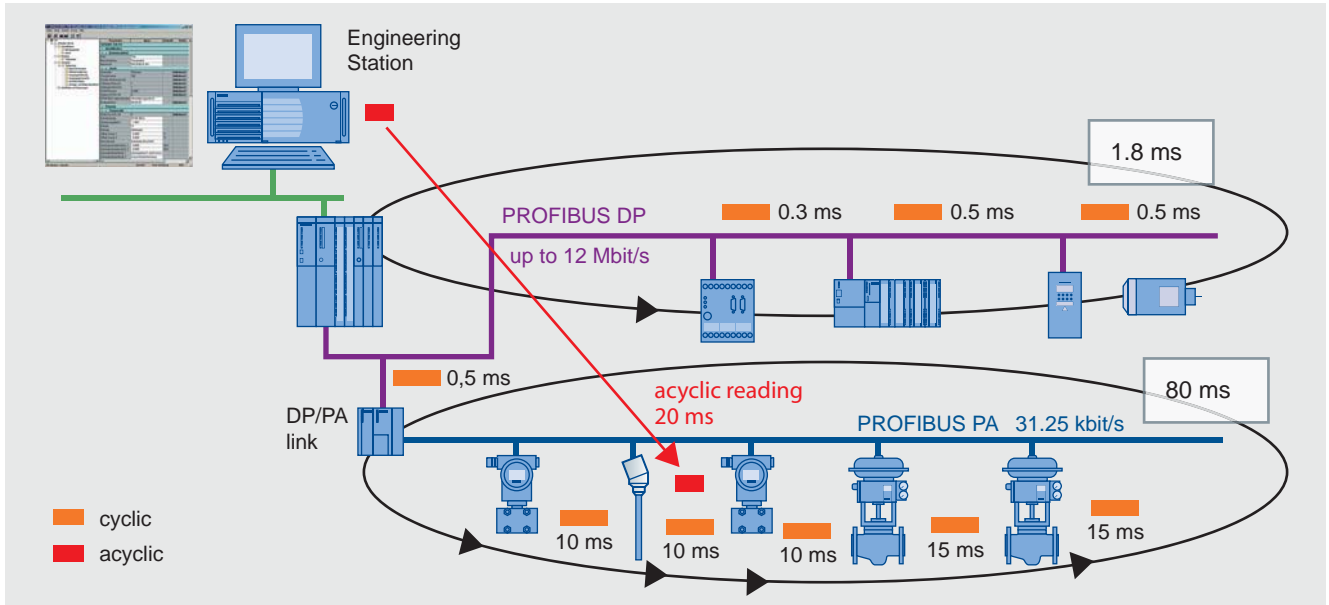

Practical example of cycle times with PROFIBUS PA

PROFIBUS cycle times and response times of the devices

Fast recording of measured values is particularly important with sensitive controls. In order to permanently guarantee chronological processing of measured values (input, processing, output), it is necessary for the PROFIBUS communications cycle to be twice as fast as the controller's processing cycle. As a result of its high data transfer rate and the correspondingly low cycle time for process operations, the PROFIBUS DP cycle can be neglected when calculating the total communication cycle since this is primarily dependent in systems with DP and PA segments on the cycle time of the PROFIBUS PA segment.

The PROFIBUS PA cycle time depends on the total number of devices connected to a DP/PA link and the transmission time that each device requires to communicate its cyclic device data. In addition, a window is reserved within a cycle for acyclic communication. Equations and examples for calculation of PROFIBUS cycle times are shown on the right.

In the practical example (see figure above), the total PROFIBUS PA cycle time is calculated to be 80 ms. As a result, the controller can be set to a minimum processing cycle of 160 ms, or higher depending on the process requirements. In the example, 20 ms are reserved in addition to the cyclic communication for the transmission of acyclic parameter data or diagnostics data from the master. The transmission of one variable, e.g. pressure or temperature, is 10 ms, each additional variable approx. 1 to 2 ms.

PROFIBUS DP cycle time (Dpt):

$Dp_t = NbDP \cdot [OvPB + BitDP \cdot (NbE + NbA)] / BdsDP$
e.g. for 30 DP slaves:

Dpt = 14.2 ms

$= 30 \cdot [317 \text{ bit} + 11 \text{ bit/byte} \cdot (244 \text{ byte} + 244 \text{ byte})] / 12 \text{ Mbit/s}$

PROFIBUS PA cycle time (PA_t):

$PA_t = NbPA \cdot [OvPB + BitPA \cdot NbByte] / BdsPA$
e.g. for 1 PA slave:

PA_t = 11.4 ms

$= 1 \cdot [317 \text{ bit} + 8 \text{ bit/byte} \cdot 5 \text{ byte}] / 31.25 \text{ kbit/s}$

Calculation of the PROFIBUS cycle times

Description	PROFIBUS DP	PROFIBUS PA
Number of slaves	NbDP	NbPA
Overhead PROFIBUS message frame	OvPB = 317 bit	OvPB = 317 bit
Data format	BitDP = 11 bit/byte	BitPA = 8 bit/byte
Number of bytes	Typical	NbByte = 5 byte
	Input	NbE = max. 244 byte
Output	NbA = max. 244 byte	
Transmission speed	BdsDP = 12 Mbit/s	BdsPA = 31.25 kbit/s

Application example

Norsk Hydro Energy – oil & gas platform, Norway



Picture source: Terje Knudsen for Norsk Hydro

Requirements

Norsk Hydro Energy operates the largest platform in the North Sea for oil and gas exploitation. This platform was to be modernized with the continuation of operation.

The objective was to convert an existing TELEPERM M system step-by-step to SIMATIC PCS 7.

Solution

Norsk Hydro Energy automates its oil platform using the SIMATIC PCS 7 process control system. Communication is implemented with PROFIBUS. The configured plant structure is thus uniform down to the field level. In addition to distributed standard I/Os, safety-oriented I/Os are also used on the PROFIBUS. PROFIBUS' profile structure satisfies all prerequisites for the field of application described.

Benefits

The complete modernization of the plant was carried out with the continuation of operation. It was not necessary to switch off the extraction processes.

A large number of measuring points were connected over the PROFIBUS. Since it was possible to use the SIMATIC S5 I/Os further, the investments of Norsk Hydro Energy could be highly safeguarded.

Application example

Bitburger brewery, Germany

Requirements

Approximately 200,000 bottles of beer of different types are produced at Bitburger every day. The Bitburger brewery Th. Simon GmbH has already been using automation solutions with PROFIBUS since 1992.

PROFIBUS PA was to be used for the modernization of a plant, since this had been applied successfully to the automation of fermenting and storage procedures since 1997.

Solution

The plant is automated with SIMATIC S5. Communication between these PLCs and the process I/O is over PROFIBUS. The intelligent field devices are integrated using PROFIBUS PA.



Benefits

PROFIBUS was highly suitable for the project because of its possibilities for implementing multimaster systems. To safeguard previous investments, existing plant components could be readily linked to the new ones. The connection and disconnection of PROFIBUS PA devices was possible without influencing other components involved in communication.

Through the use of PROFIBUS, the costs compared to conventional technology could be reduced by more than 50%. The uniform field communication over PROFIBUS provides Bitburger with even more advantages. In addition to the high measuring accuracy and consistent data management throughout the plant, these advantages primarily concern more effective diagnostics, maintenance and repair.









Distributed I/O devices







Distributed I/O devices	PA	DP	PDM	Safety	Description	Functions
		■		■	ET 200M Modular remote I/Os for process control applications with SIMATIC PCS 7 in IP20 degree of protection <ul style="list-style-type: none"> Permits transmission rates on the PROFIBUS up to 12 Mbit/s Permits redundancy of the PROFIBUS interfaces Can be installed in Ex zone 2, and the connected actuators and sensors also in Ex zone 1 	Wide range of I/O modules of S7-300 design (up to 8 per station): <ul style="list-style-type: none"> DI, DO, AI, AO signal modules (simple, with diagnostics capability, redundant and Ex version) Function modules (controllers, counters) HART modules F-modules for fail-safe applications Support of online modifications: <ul style="list-style-type: none"> Addition of station Addition of I/O modules Parameter assignment.
		■			ET 200iSP Intrinsically-safe, modular I/O system with independent wiring and IP30 degree of protection for up to 32 electronics modules <ul style="list-style-type: none"> Permits transmission rates on the PROFIBUS up to 1.5 Mbit/s Permits redundancy of the PROFIBUS interfaces Can be installed directly in Ex zones 1, 2, 21 or 22, connected sensors/actuators also in Ex zone 0 	Available electronics modules: <ul style="list-style-type: none"> DI NAMUR DO AI for temperature measurements using resistance thermometer/thermocouple AO AI HART (for two-wire and four-wire transmitters) AO HART Support of online modifications: <ul style="list-style-type: none"> Addition of station Expansion of station with modules Modification of module parameters Replacement of individual modules during operation without fire certificate
		■		■	ET 200S Bit-modular, extremely compact I/O system with independent wiring and IP20 degree of protection <ul style="list-style-type: none"> Permits transmission rates on the PROFIBUS up to 12 Mbit/s Can be installed in Ex zone 2 	Range of I/Os comprises: <ul style="list-style-type: none"> Power modules DI, DO, AI and AO signal modules Integral motor starters up to 7.5 kW. Support of online modification function "Add station"

Abbreviations: PA: can be connected to PROFIBUS PA
 DP: can be connected to PROFIBUS DP
 PDM: parameters can be assigned using SIMATIC PDM
 Safety: with PROFIsafe profile









Drives

Drives		PA	DP	PDM	Safety	Description	Field of application	
Motor management								
		■	■			Motor management and control devices SIMOCODE pro (can be integrated in SIMATIC PCS 7 using PCS 7 block library)	Flexible and modular motor management system for motors with constant speeds in the low-voltage range. <ul style="list-style-type: none"> Power range 0.1 to 560 kW Voltages up to 690 V AC Rated motor currents up to 820 A Functional extensions possible using expansion modules.	Can be used wherever solid, liquid or gaseous materials have to be moved, conveyed, pumped or compressed, e.g. for operation of: <ul style="list-style-type: none"> Pumps and fans Compressors Extruders and mixers Mills
Frequency converter								
		■	■			MICROMASTER 4 (can be integrated in SIMATIC PCS 7 using PCS 7 block library)	Standard frequency converter with high dynamic performance for variable-speed drives <ul style="list-style-type: none"> Power range 0.12 to 250 kW Voltages from 200 to 600 V 	For universal use, especially for: <ul style="list-style-type: none"> Operation of pumps and fans In conveyor systems
		■				SIMOVERT MASTERDRIVES VC and MC	Uniform, modular frequency converter range for highly exact variable-speed AC motors (individual and multi-motor drives) <ul style="list-style-type: none"> Vector Control (VC): three-phase drives with vector control for continuous processes Motion Control (MC): servo drives for cyclic machines with high dynamic performance Power range 0.55 to 2,300 kW Voltages up to 690 V 	Can be used for highly efficient drive solutions in all sectors (also in harsh operating environments), e.g. in: <ul style="list-style-type: none"> Steel and rolling mill works Packaging, printing and paper industry Plastics processing and manufacture Woodworking and textile processing Conveyor systems
		■				SIMOREG DC Master	Converter range with high dynamic performance for control of DC motors <ul style="list-style-type: none"> Power range 6.3 to 2,000 kW Voltages from 400 to 830 V Current or torque rise time < 10 ms Intelligent parallel connection permits redundant drive solutions up to 12,000 A 	Can be used for standard applications as well as high-performance solutions, in particular: <ul style="list-style-type: none"> Paper and printing industry Rubber and plastics industry Drives of hoisting gear Lift and ropeway drives Steel industry (shear drives) Rolling mill drives Winding drives Loading machines for motor, turbine or gear test bays
		■				SINAMICS G120	Modular frequency converter for variable-speed AC motors and gearmotors <ul style="list-style-type: none"> Power range 0.37 to 90 kW Voltage range 380 to 480 V Vector control Safety Integrated functions Line-commutated energy recovery 	For universal use in many sectors, e.g. machine construction, automotive and textile industries. Particularly suitable for <ul style="list-style-type: none"> Pumps and fans Conveyor systems Packaging machines
		■				SINAMICS G150	AC/AC converter in standard switch-gear cabinet for variable-speed individual drives of high power <ul style="list-style-type: none"> Power range 75 to 800 kW <ul style="list-style-type: none"> 110 to 560 kW with mains voltages from 380 to 480 V 75 to 800 kW with mains voltages from 660 to 690 V 	Can be used to advantage wherever solid, liquid or gaseous materials have to be moved, conveyed, pumped or compressed, i.e. for <ul style="list-style-type: none"> Pumps and fans Compressors Extruders and mixers Mills







Measuring equipment

Measuring equipment	PA	DP	PDM	Safety	Description	Field of application	
Flow rate							
	■	■	■	■	SITRANS F C MASSFLO MASS 6000	Universal flowmeters of Coriolis design Measurements independent of changes in process conditions and parameters such as temperature, density, pressure, viscosity, conductivity and flow profile	Mass flowmeter for measuring all types of liquids and gases Main areas of use: <ul style="list-style-type: none"> Water and wastewater Chemical plants and pharmaceuticals Oil and gas industries Food and beverages industry
	■	■	■	■	SITRANS F M MAGFLO MAG 6000	Universal flowmeters of electromagnetic design	For almost all electrically conducting liquids, suspended matter, slurries, sludges Main areas of use: <ul style="list-style-type: none"> Water and wastewater Chemical plants and pharmaceuticals Food and beverages industry Steel industry
	■	■	■	■	SITRANS FM Transmag 2	Universal flowmeters of electromagnetic design with pulsed alternating field	Thanks to the high magnetic field strength, particularly suitable for media with high solids content, e.g. <ul style="list-style-type: none"> Paper and cellulose masses with concentrations > 3% Mining sludges (highly concentrated / with magnetic particles)
Pressure							
	■	■	■	■	SITRANS P DS III	Digital pressure transmitter with high accuracy and comprehensive diagnostics and simulation functions Measuring range from 1 mbar (DS III) or 8 mbar (P300) to 400 bar	Measurement of <ul style="list-style-type: none"> Relative pressure, absolute pressure and level (P300) as well as additive Differential pressure and flow (DS III) of corrosive and non-corrosive gases, vapors and liquids, also under extreme chemical and mechanical loads or strong electromagnetic influences Also for hazardous areas Zone 1 or 21
	■	■	■	■	SITRANS P300	Series P300 satisfies the special design requirements of the food and pharmaceutical industries as well as biotechnology	
Temperature							
	■	■	■	■	SITRANS TK T3K PA	Digital transmitter with various diagnostics and simulation facilities, for signals from <ul style="list-style-type: none"> resistance thermometers, resistance-based sensors, thermocouples and voltage sensors 	Temperature transmitter for use in all sectors Suitable for mounting in the connection head type B Also for hazardous areas Zone 1 or 21
Level, capacitive							
	■	■	■	■	Pointek CLS 200/300	Capacitive level switch with inverse frequency shift technology, extremely resistant to chemicals, for use in harsh environments, e.g. at relatively high pressures and temperatures	Level measurements (point level) for <ul style="list-style-type: none"> Liquids and interfaces Fine bulk material (powders, granulates) Sludges and foams Sticky materials (CLS 300) Simple pump control (CLS 200)
	■	■	■	■	SITRANS LC 300	Low-cost capacitive level meter with high precision	For liquids and bulk materials, also with moisture, steam, foam, temperature/pressure variations as well as deposits, particularly in <ul style="list-style-type: none"> Chemical plants and pharmaceuticals Food and beverages industry

Measuring equipment

Measuring equipment	PA	DP	PDIM	Safety	Description	Field of application
Level, radar						
	■	■	■	■	SITRANS LR 200 2-wire pulse radar (loop current) for cost-effective level measurements	Non-contact level measurement of liquids in storage tanks or simple process containers under harsh environmental conditions, particularly in the chemical and pharmaceutical industries
	■	■	■	■	SITRANS LR 300 Powerful pulse radar for non-contact level measurement of liquids and sludges under extreme process conditions ■ Measuring range up to 20 m	For liquids and sludges in storage tanks, process containers, reactors or digestion tanks, also under extreme process and environmental conditions Main areas of use: chemical/petrochemical plants and pharmaceuticals
	■	■	■	■	SITRANS LR 400 Powerful FMCW level radar for large measuring ranges and extreme process conditions ■ Two different versions for liquids and bulk materials ■ Measuring range up to 50 m	Non-contact level measurement of liquids and bulk materials, especially where large amounts of dust are produced or liquids with low dielectric constant Main areas of use: manufacture and processing of products generating dust, e.g. cement, coal, flour
Level, ultrasonic						
	■	■	■	■	SITRANS Probe LU Compact 2-wire ultrasonic meter for level and volume measurements of liquids in storage tanks and simple process containers as well as for flow measurements in open canals ■ Continuous measurement up to 12 m	Non-contact level, volume and flow measurement of liquids, especially in the water and wastewater industry and with the storage of liquid materials in almost all industrial sectors
	■	■	■	■	MultiRanger 100/200 Universal single-channel or multi-channel ultrasonic transmitter for small to medium measuring ranges. ■ Compatible with the chemically resistant Echomax sensors for temperatures up to 145 °C	Non-contact level, volume and flow measurement as well as enhanced pump control for liquids, sludges and bulk materials in almost all industrial sectors
	■	■	■	■	HydroRanger 200 Ultrasonic transmitter for up to six pumps, permitting level control, difference measurement and flow measurements in open canals.	For monitoring water and wastewater of any consistency down to a depth of 15 m Main areas of use: monitoring of pump shafts, weirs and canals, and for screen control
	■	■	■	■	SITRANS LU 01/02/10 Ultrasonic transmitter for level measurements of liquids and bulk materials in a range of max. 60 m ■ Sensor distance up to 365 m ■ Compatible with Echomax sensors	Non-contact measurement of level, empty space, distance, volume or mean/difference value, especially for the storage of liquids, bulk materials or their mixtures in containers of different shape, size and configuration
	■	■	■	■	SITRANS LUC 500 Complete system for monitoring and control of water/wastewater with exact ultrasonic level measurement up to 15 m and reliable flow measurement in open canals	Monitoring and control of water supply plants and wastewater collection systems

Process controllers and positioners, process monitoring, weighing and dosing systems

Process controllers	PA	DP	PDM	Safety	Description	Field of application
		■	■		SIART DR 19/21 Compact controllers designed as standard as continuous and step controllers	Wide range of predefined functions for controlling industrial processes, and their application does not require any programming knowledge or auxiliary equipment
Positioners						
	■		■		SIART PS2 Electropneumatic positioners <ul style="list-style-type: none"> Numerous integral diagnostics functions provide information on the status of valve and drive Automatic startup function with self-adjustment for fast adaptation to the respective fitting 	Highly exact control of valves and dampers using linear and rotary actuators, also in hazardous areas Zone 1 or 21
Process monitoring						
	■	■	■		SITRANS DA400 Acoustic sensor for monitoring diaphragm piston pumps	The SITRANS DA400 allows continuous, simultaneous and independent monitoring of up to four delivery valves in a pump for leaks. In addition, another four inputs are available for monitoring standard signals. This means that the condition of an oscillating displacement pump is monitored in every phase of its operation.
Weighing and dosing systems						
		■			SIWAREX M/U/FTA/FTC SIWAREX weighing systems consist of a SIWAREX M, U, FTA or FTC weighing processor with one or more load cells for operation in the ET 200M.	Can be used in the complete manufacturing process: <ul style="list-style-type: none"> Hopper, platform, vehicle and dosing scales Weighing bridges In filling plants On conveyor belts
		■			Milltronics BW 500 Powerful transmitter for belt scales and weighfeeders	The Milltronics BW 500 is a powerful transmitter for belt scales and weighfeeders. It can be used with all belt scales with up to four strain gauge load cells. It processes weight and speed signals for exact display of the transferred quantity and total quantity of bulk materials.
		■			Milltronics SF 500 Powerful transmitter for use with discharge flowmeters	The Milltronics SF 500 is a powerful transmitter for use with discharge flowmeters. It can be used with all discharge flowmeters with up to two strain gauge load cells or LVDT sensors. The sensor signals are processed to achieve exact calculation of throughput and total quantity.

Gas analyzers

Gas analyzers							
	PA	DP	PDIM	Safety			
	■	■	■		CALOMAT 6	Exact determination of composition and concentration of process gases using thermal conductivity procedure	e.g. measurement of hydrogen and inert gas concentrations in blast furnace gas and carbon dioxide mixtures
	■	■	■		ULTRAMAT 23	Low-price multi-component NDIR analyzer for a wide variety of standard applications	e.g. flue gas monitoring, furnace optimization, room air monitoring, can be equipped with additional electrochemical cell for oxygen measurements
	■	■	■		ULTRAMAT 6	Analyzer for measurement of up to four components which are IR-active	In all sectors from emission measurements up to production procedures, even in the presence of highly corrosive gases
	■	■	■		OXYMAT 6	Corrosion-resistant oxygen analyzer for use in harsh atmospheres	Suitable for emission measurements, for guaranteeing product quality, or for monitoring production processes, in particular with safety-relevant plants
	■	■	■		ULTRAMAT/OXYMAT 6	ULTRAMAT/OXYMAT combination with <ul style="list-style-type: none"> ■ one infrared channel for measurement of one or two IR components and ■ one channel for measurement of oxygen 	
	■	■	■		OXYMAT 61	Low-price oxygen analyzer for standard applications	

Technical specifications

Technical specifications	PROFIBUS			PROFIBUS PA
Data transmission	RS 485	RS 485-iS	Fiber-optic	MBP
Data transfer rate	9.6 kbit/s ... 12 Mbit/s	9.6 kbit/s ... 1.5 Mbit/s	9.6 kbit/s ... 12 Mbit/s	31.25 kbit/s
Cable	Two-wire shielded	Two-wire shielded	Plastic as well as multi-mode and single-mode glass fiber	Two-wire shielded
Type of explosion protection		EEx(ib)		EEx(ia/ib)
Topology	Linear, tree	Linear	Ring, star, linear	Linear, tree
Participants per segment	32	32 ¹⁾	–	32
Participants per network (with repeater)	126	126	126	126
Cable length per segment depending on transmission rate	1200 m at max. 93.75 kbit/s 1000 m at 187.5 kbit/s 400 m at 500 kbit/s 200 m at 1.5 Mbit/s 100 m at 12 Mbit/s	1000 m at 187.5 kbit/s ¹⁾ 400 m at 500 kbit/s ¹⁾ 200 m at 1.5 Mbit/s ¹⁾	Max. 80 m (plastic) 2-3 km (multi-mode glass fiber) >15 km at 12 Mbit/s (single-mode glass fiber)	1900 m: standard 1900 m: EEx(ib) 1000 m: EEx(ia)
Repeater for signal boosting with RS 485 networks	Max. 9	Max. 9 ¹⁾	Not relevant	Not relevant

¹⁾ In accordance with PROFIBUS installation guideline 2.262

Further information

For further details, see SIMATIC Guide Technical Documentation: www.siemens.com/simatic-docu

You can order more publications on the subject of SIMATIC at: www.siemens.com/simatic/printmaterial

For a personal discussion, you can locate your nearest contact: www.siemens.com/automation/partner

In the A&D Mall you can place orders electronically via the Internet: www.siemens.com/automation/mall

Further products sites

- Controllers: www.siemens.com/controller
- ET 200 distributed I/O: www.siemens.com/ET200
- Drives: www.siemens.com/motioncontrol
- Process instrumentation: www.siemens.com/processinstrumentation
- Process analytics: www.siemens.com/processanalytics
- Weighing technology: www.siemens.com/weighing-technology

PROFIBUS International

PROFIBUS International: www.profibus.com

Siemens AG

Automation and Drives
Industrial Automation Systems
P.O. Box 48 48
90327 NUREMBERG
GERMANY

www.siemens.com/profibus

The information provided in this brochure contains descriptions or characteristics of performance which in case of actual use do not always apply as described or which may change as a result of further development of the products. An obligation to provide the respective characteristics shall only exist if expressly agreed in the terms of contract. Availability and technical specifications are subject to change without prior notice.

All product designations may be trademarks or product names of Siemens AG or supplier companies whose use by third parties for their own purposes could violate the rights of the owners.